

MLC 420

PORTABLE

REFERENCE POINT

MAGNETIC LINEAR SCALES



- Incremental Encoder Output A, B, Z, / A, / B, / Z
- Portable Reference Point
- Stroke Values up to 2000 mm
- Socket Building
- Perfect Retention System
- High Stability
- IP65 Protection Class
- Easy Installation
- Same Ruler Available Right or Left
- Delem, Cybelec and ESA Compatible with Devices

OPERATION

MANUAL

1. WARNINGS

1. Connections must be completed by only authorized personnel.
2. Consider the warnings when completing the connections and using the scale.
3. Pay attention about the sensors power supply. (For TTL sensor max. 5V, for Push-Pull sensor max. 30V). Don't energize the scale before all connections completed.
4. Distance between sensor and control unit must be short as possible. Avoid additions except the suitable connector unless it needs.
5. Be away the sensor cable from high power cables, contactor, engine, or inductive and capacitive noise sources.
6. The screen cable must be connected to the earth line.
7. The magnetic tape must be away from magnetic areas.
8. The proximity of the band with comparator, magnet or similar instruments having a magnetic effect, disrupts the working structure of the band.
9. Don't make any connection when the scale energized.
10. Please call the service for any problem about the scale.
11. Transport and storage should be at their original packaging and an ambient temperature of -25°C / +85°C in such a way that they will not be exposed to dust, humidity, impact, vibration, falling or water.
12. Chemicals such as alcohol, thinner etc. should not be used for cleaning the product. The product should be wiped with a damp cloth.
13. The product may be damaged and may become unusable if used outside of the specifications in the user manual. In this case, the product will be out of warranty.



2. GENERAL INFORMATION

These scales are used to achieve the best performance until the measurement up to 2040 in high speed and vibrotary area. Thanks to the it's montage point and design, the faults that are appear due to temperature variation are minimized. On the other hand, the all precautions that is caused by machine are taken. Thanks to the Ergonomic design , cable output don't block the scale and works in a stability.



Thanks to the reference point, the side of the MLC 420 that is send by production as a left or right can be changed by user.

PRODUCT CODE

															Power Supply and Output			Cable Length					Measuring distance		
															TTL : 5VDC Supply Voltage, 5 VDC TTL RS422 Line Driver Signal Output PP : 10...30 VDC Supply Voltage, 10...30 VDC Push-Pull Signal Output HTL : 10...30 VDC Supply Voltage, 5 VDC TTL RS422 Line Driver Signal Output HPL : 5...30 VDC Supply Voltage, 5...30 VDC Push-Pull Signal Output			3M : 3 meters 3.5M : 3,5 meters 4M : 4 meters 5M : 5 meters 6M : 6 meters 7M : 7 meters 8M : 8 meters 9M : 9 meters 10M: 10 meters 15M: 15 meters * Please ask for other options					See standard stroke lengths table, contact for other stroke lengths.		
															Magnetic tape										
															B2										
MLC420	-	X	X	-	X	X	-	X	X	X	-	X	-	X	X	-	X	-	X	X	X	mm	-	X	
Model	Resolution					Signal output type					Sensor/Cable Type					Right/Left									
	01 : 1µm 05 : 5µm 10 : 10µm 25 : 25µm 50 : 50µm					2 : A, B 3 : A, B, Z 4 : A, /A, B, /B 6 : A, /A, B, /B, Z, / Standard, single Z reference signal Optional, Z signal at every 2 mm					C : PUR cable					L : left R : right									

3. TECHNICAL SPECIFICATION

Technical Specification

Operation Temperature	- 25 to 85 °C
Storage Temperature	- 40 to 100 °C
Protection Class	IP65
Body	Aluminum
Magnetic Tape Type	B2
Reading Tape Distance	1,5 mm
Operation Speed	3 m/s max.
Connection	D-Sub 9 Pin, 5 or 8 x 0,14 mm ² shielded cable
Accuracy	± 40 µm
Repeatability	± 1 pulse

ELEKTRICAL SPECIFICATIONS

Power Supply	5 Vdc, +10 Vdc...+30Vdc
Current Supply	40 mA/per channel max.
Output Type	TTL, Push Pull Line Driver
Output Signal	A, /A, B, /B, Z, /Z
Output Current	40 mA/per channel max.
Immunity	EN-61000-6-2:2005

DIMENSIONS

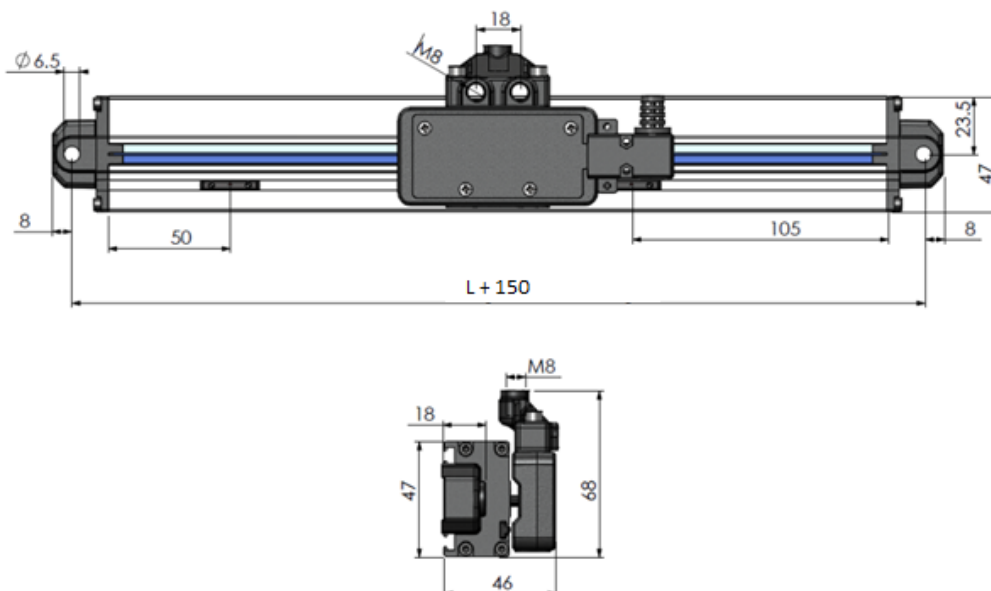

Standard Measuring Lengths (L) *

100	120	150	170
200	220	250	270
300	320	350	370
400	420	450	470
500	520	550	570
600	650	700	750
800	850	900	950
1000	1100	1200	1300
1400	1500	1600	1700
1800	2000		

4. CONNECTION

4.1. Pin Connections

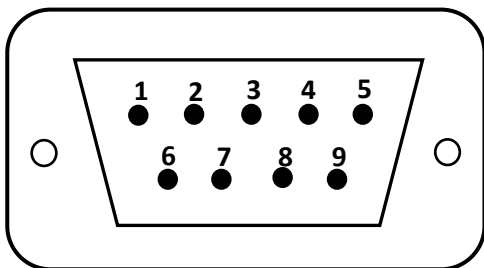

In the below table the cable color of the sensor output signals is given. If the control circuit is suitable in the Line Driver sensors the output signal inverts (/A, /B, /Z) must be included in the system. If the control circuit is not suitable for this application /A, /B, /Z signal cables must be immobilized separately isolated. Don't forget that there are also currents on these cables.

Pin Number	Cable Color	Signal
1	Yellow	A
2	White	/B
3	Red	POWER SUPPLY
4	Black	0 V
5	Blue	/A
6	Green	B
7	Grey	/Z
8	Pink	Z
9	SHIELD	GROUND

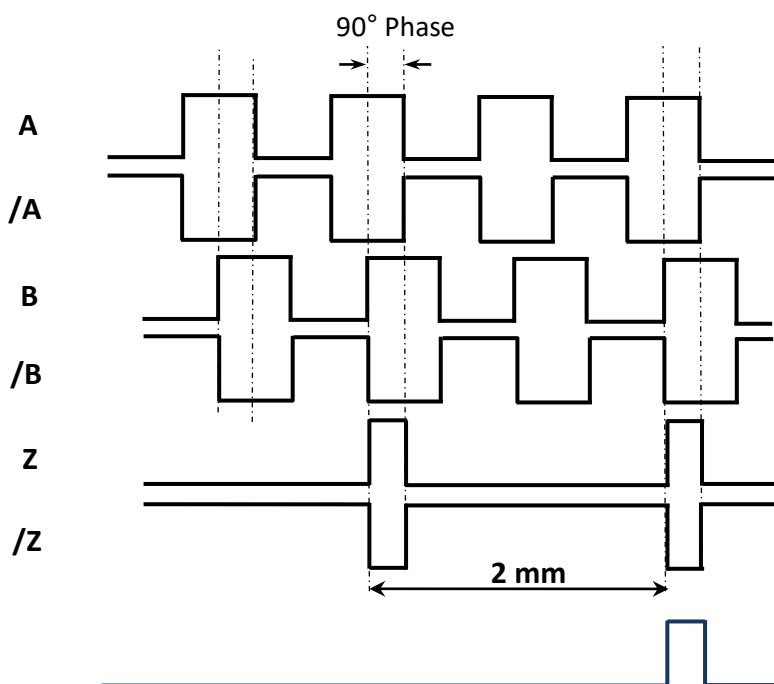

Optional
Every 2 mm, Z Pulse

Standard
One "Z" Reference Signal
(for example at the start point)

4.2. Reference Point Changing (Right/ Left Changing)

MLC 420, thanks to the movable reference point you can change the factory output directions. For example the scales which is produced as right side can be return to the left side scale.

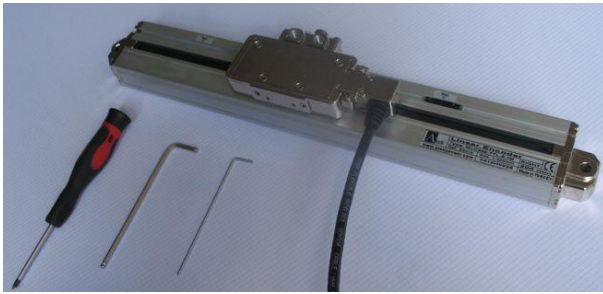

For this operation a phillips screwdriver, a 1,5 mm allen, a 3 mm allen are needed.

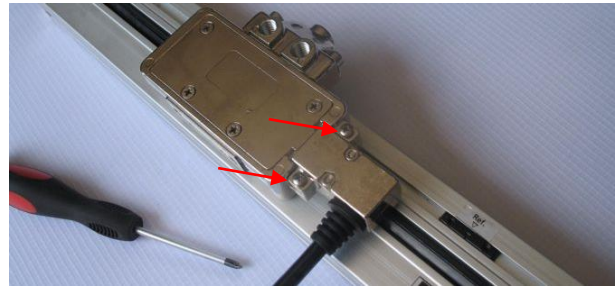

The connector is detached by phillips screwdriver.

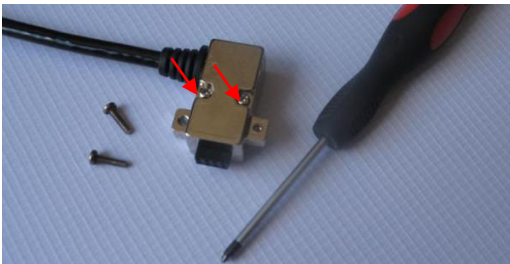

After detaching the connector open it by phillips screwdriver to change the cable direction..

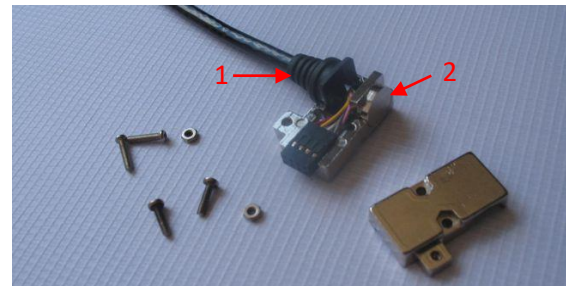

Change the cable (1) and protection cover (2) places. And close the connector.



The connector is put on its place. The screws is closed again by Phillips screwdriver. Anymore the cablo is on the other side.

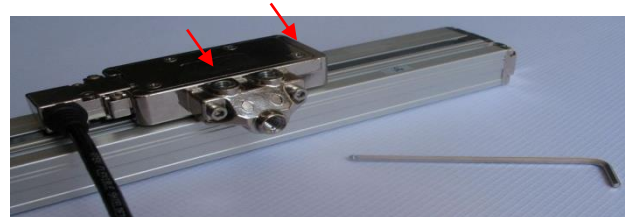

The set screw screwdrivers of top installation head are loosened with 3 mm allen and top connection head is removed.



The top installation head that is removed is screwed to the sensor's other side with the help of the allen.



Reference determining's set screw screws are removed to change the reference point with 1,5 mm allen and drifted to the other reference point. Set screw are squeezed again.

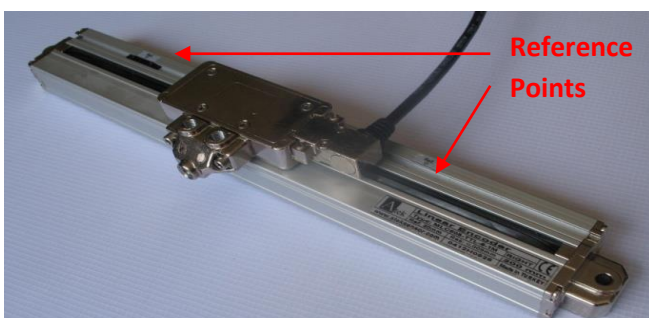

Anymore MLC 420 can be used as a left scale.

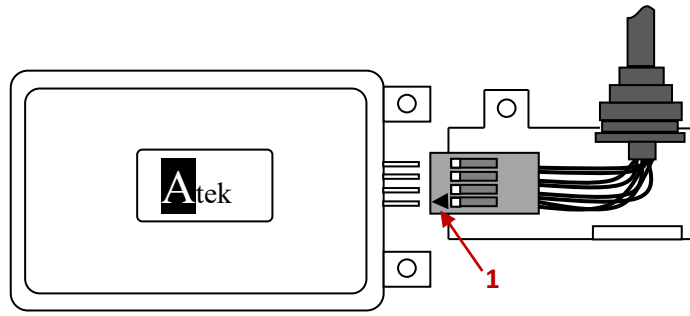

WARNING !!!

When you are changing the cable place, pay attention to the arrow (1) must be like the figure.

4.3. Montage

Installation the MLC 420 is an important point in terms of the proper system function. The reader head is bearded in the profile, the distance between the profile and reader head is constant. The parallelism between the reader head and profile should stay same during the whole distances. The scale and reader head body should be set with the proper equipments like comparator during the montage stage.

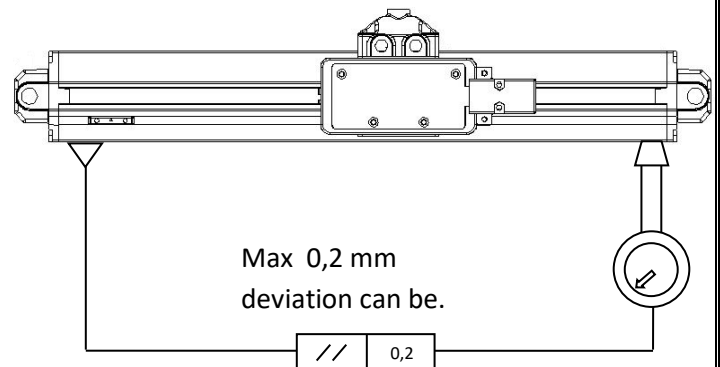
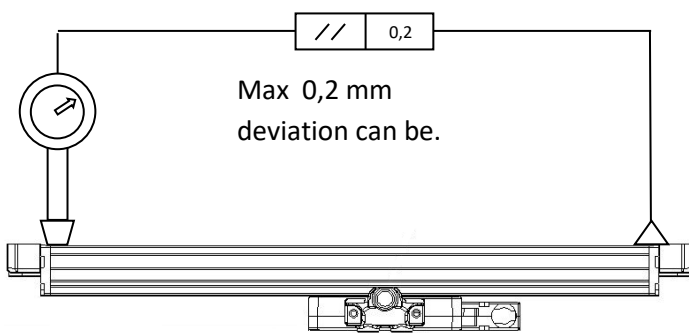

KEEP AWAY FROM THE STRONG MAGNETIC AREA

EXAMPLE OF THE MLC 420 R&L (RIGHT AND LEFT) SENSOR APPLICATION

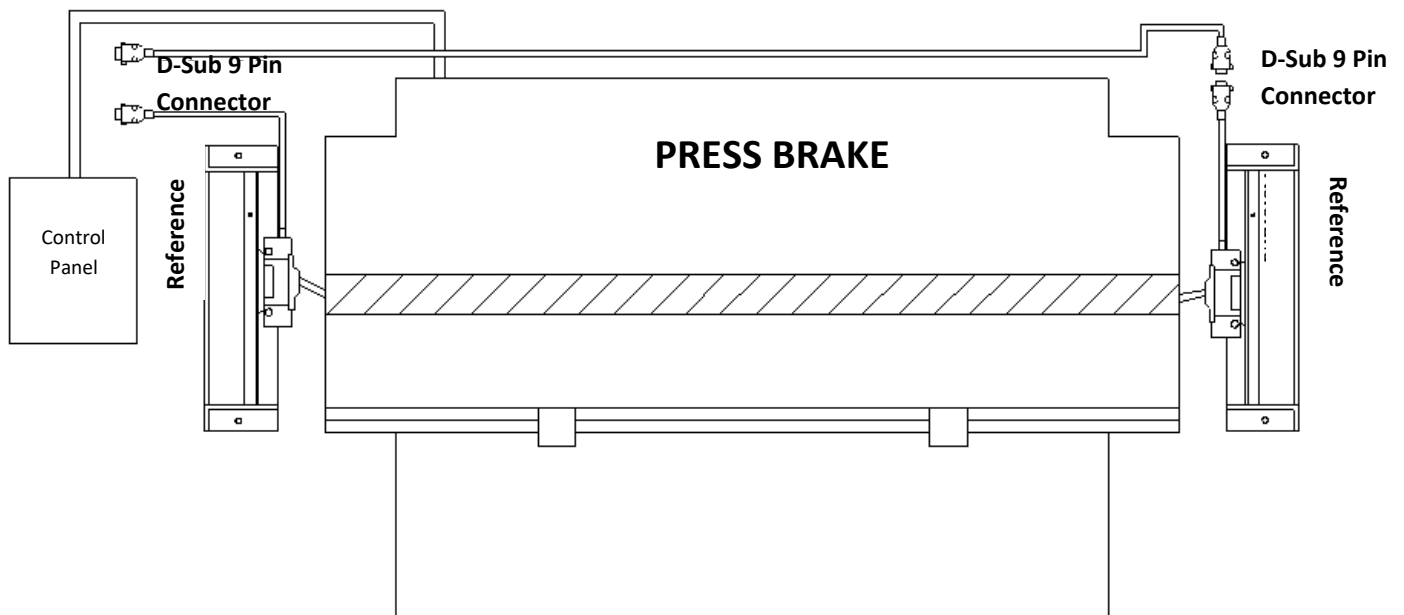

*Other Socket Connections

S41 Socket

Pin Number	Cable Color	Signal
1	RED	POWER SUPPLY
2	BLACK	GROUND
3	YELLOW	A
4	PINK	Z
5	GREEN	B
6	WHITE	/B
7	GREY	/Z
8	BLUE	/A
9	-	-

S87 Socket

Pin Number	Cable Color	Signal
1	-	-
2	RED	POWER SUPPLY
3	BLACK	GROUND
4	BLUE	/A
5	YELLOW	A
6	WHITE	/B
7	GREY	/Z
8	PINK	Z
9	GREEN	B

S86 Socket

Pin Number	Cable Color	Signal
1	PINK	Z
2	GREEN	B
3	YELLOW	A
4	-	-
5	BLACK	GROUND
6	GREY	/Z
7	WHITE	/B
8	BLUE	/A
9	RED	POWER SUPPLY

S71 Socket

Pin Number	Cable Color	Signal
1	BLACK	GROUND
2	BLUE	/A
3	WHITE	/B
4	GREY	/Z
5	RED	POWER SUPPLY
6	YELLOW	A
7	GREEN	B
8	PINK	Z
9	-	-

S50 and S58 Socket

Pin Number	Cable Color	Signal
1	PINK	Z
2	GREY	/Z
3	RED	POWER SUPPLY
4	-	-
5	BLACK	GROUND
6	YELLOW	A
7	BLUE	/A
8	WHITE	/B
9	GREEN	B

S42 Socket (SINO Connection)

Pin Number	Cable Color	Signal
1	BLUE	/A
2	BLACK	GROUND
3	WHITE	/B
4	-	-
5	GREY	/Z
6	YELLOW	A
7	RED	POWER SUPPLY
8	GREEN	B
9	PINK	Z

S57 Socket

Pin Number	Cable Color	Signal
1	YELLOW	A
2	BLUE	/A
3	-	-
4	PINK	Z
5	GREY	/Z
6	-	-
7	-	-
8	BLACK	GROUND
9	-	-
10	GREEN	B
11	WHITE	/B
12	-	-
13	-	-
14	-	-
15	RED	POWER SUPPLY

S43 Socket

Pin Number	Cable Color	Signal
1	YELLOW	A
2	BLUE	/A
3	GREEN	B
4	WHITE	/B
5	PINK	Z
6	GREY	/Z
7	-	-
8	-	-
9	RED	POWER SUPPLY
10	-	-
11	BLACK	GROUND
12	-	-
13	-	-
14	-	-
15	SHIELD	GND

ATEK ELEKTRONİK SENSÖR TEKNOLOJİLERİ SANAYİ VE TİCARET A.Ş.

 Gebze OSB, 800. Sokak, No:814 Gebze/KOCAELİ/TÜRKİYE

 Tel: +90 262 673 76 00

 Fax : +90 262 673 76 08

 Web: www.ateksensor.com

 E-Mail: info@ateksensor.com