

MLC 310

COMPACT SYSTEM

MAGNETIC LINEAR SCALES

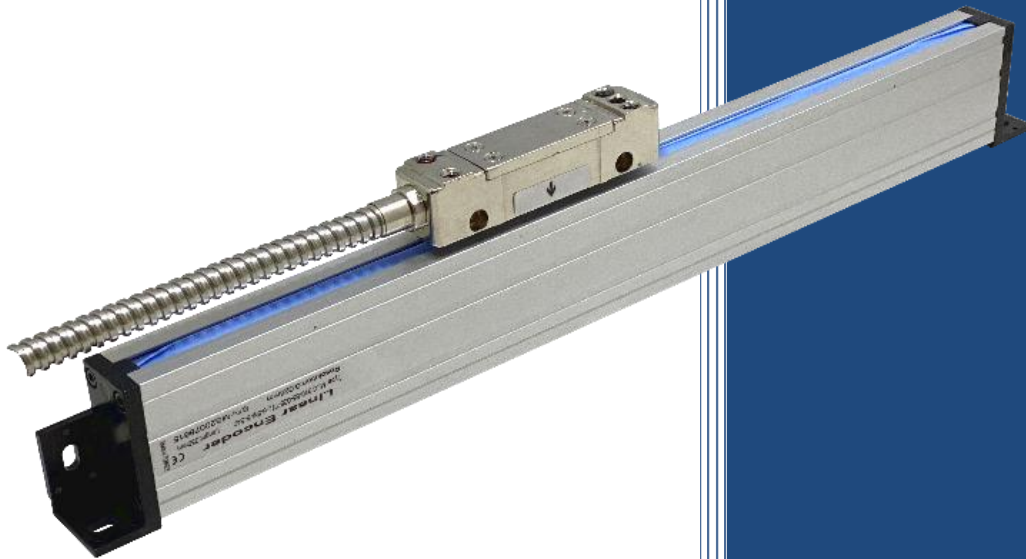

- High accuracy and repeatability
- Magnetic measurement
- Contactless / non-friction system
- High tolerance to vibration and shocks
- Measuring up to 20 meters
- Resistant to dust, oil and moisture
- No maintenance required
- Robust aluminum body
- IP67 protection class
- Easy installation

OPERATIONAL

MANUAL

1. WARNINGS

1. Connections must be completed by only authorized personnel.
2. Consider the warnings when completing the connections and using the scale.
3. Pay attention about the sensors power supply. (For TTL sensor max. 5V, for Push-Pull sensor max. 30V). Don't energize the scale before all connections completed.
4. Distance between sensor and control unit must be short as possible. Avoid additions except the suitable connector unless it needs.
5. Be away the sensor cable from high power cables, contactor, engine, or inductive and capacitive noise sources.
6. The screen cable must be connected to the earth line.
7. The magnetic tape must be away from magnetic areas.
8. The proximity of the band with comparator, magnet or similar instruments having a magnetic effect, disrupts the working structure of the band.
9. Don't make any connection when the scale energized.
10. Please call the service for any problem about the scale.
11. Transport and storage should be at their original packaging and an ambient temperature of -25°C / +85°C in such a way that they will not be exposed to dust, humidity, impact, vibration, falling or water.
12. Chemicals such as alcohol, thinner etc. should not be used for cleaning the product. The product should be wiped with a damp cloth.
13. The product may be damaged and may become unusable if used outside of the specifications in the user manual. In this case, the product will be out of warranty.



2. GENERAL INFORMATION

The encoder forms a compact unit. The scanning unit is guided within the housing along scale.

Long life linear motion guide system. The scale, scanning unit and guide are protected against contamination by an aluminum extrusion and elastic sealing lips.

The coupling elements between the scanning carriage and transfer web are designed to transfer motion in the measuring direction only.

Pitch or other motion of the connecting web in a direction perpendicular to measurement is compensated without affecting accuracy.

MLC 310 Series Linear Encoders Are Mainly Used In:



- Lathes, Milling, Drilling, Grinding Machines
- Sheet Metal Working Machines
- Welding Machines
- Bending Machines
- Robotics/Materials Handling
- Marble Machines
- Wood Cutting Machines
- PVC Profile Cutting Machines
- Glass Working Machinery
- Etc...

PRODUCT CODE

Cable Length

- 3M** : 3 meters
- 3.5M** : 3,5 meters
- 4M** : 4 meters
- 5M** : 5 meters
- 6M** : 6 meters
- 7M** : 7 meters
- 8M** : 8 meters
- 9M** : 9 meters
- 10M**: 10 meters
- 15M**: 15 meters
- * Please ask for other options

Measuring Stroke

See standard stroke lengths table, contact for other stroke lengths.

Power Supply and Output

- TTL** : 5VDC Supply Voltage,
5 VDC TTL RS422 Line Driver Signal Output
- PP** : 10...30 VDC Supply Voltage,
10...30 VDC Push-Pull Signal Output
- HTL** : 10...30 VDC Supply Voltage,
5 VDC TTL RS422 Line Driver Signal Output
- HPL** : 5...30 VDC Supply Voltage,
5...30 VDC Push-Pull Signal Output

Magnetic Tape

B5

MLC310 - X X - X X - X X X - X - X X - X - X X X mm

Model

Resolution

- 05** : 5µm | **10** : 10µm
- 25** : 25µm | **50** : 50µm
- 62** : 62,5µm | **100** : 100µm

Signal Output Type

- 2** : A, B
- 3** : A, B, Z
- 4** : A, /A, B, /B
- 6** : A, /A, B, /B, Z, /Z
- Z** : Standard, Z Signal at every 5 mm

Sensor Type

- C** : PUR Cable
- S** : Spiral

3. TECHNICAL SPECIFICATIONS

TECHNICAL

Operating Temperature	- 25 to 85 °C
Storage Temperature	- 40 to 100 °C
Protection Class	IP67
Body	Aluminum
Magnetic Tape	B5
Tape Reading Distance	0,1 to 2 mm
Operating Speed	3 m/s max.
Connection	D-Sub 9 Pin, 5 or 8 x 0,14 mm ² shielded cable
Accuracy	± 40 µm/m max.
Repeatability	± 1 pulse

ELECTRICAL

Power Supply	5 Vdc, +10 Vdc...+30Vdc
Current Consumption (max.)	40 mA / channel
Output	TTL, Push Pull Line Driver
Output Signals	A, /A, B, /B, Z, /Z
Output Current	40 mA / channel

MECHANICAL DIMENSIONS

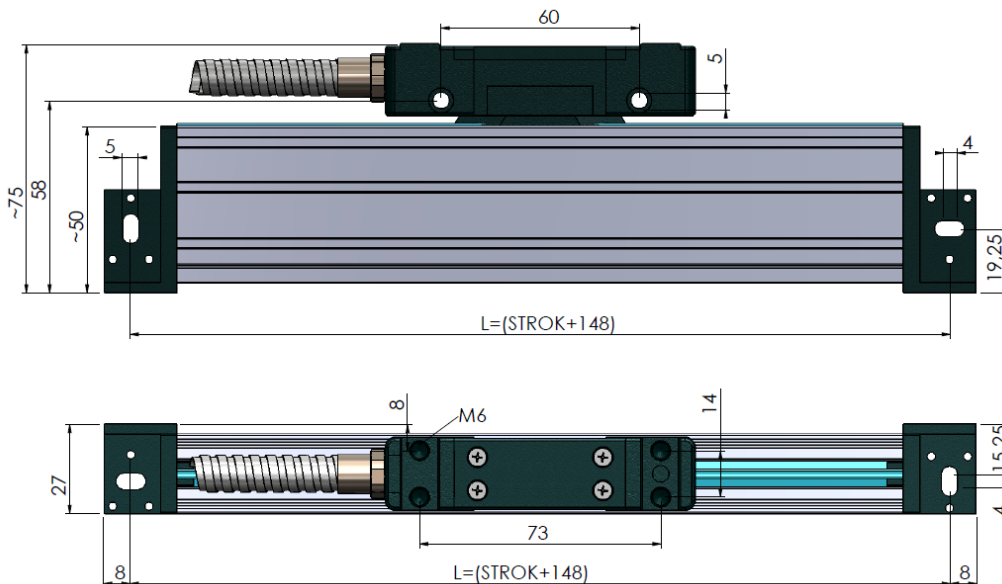

Standard Stroke Lengths (mm)

100	120	150	170	200	220	250	270	300	320
350	370	400	420	450	470	500	520	550	570
600	650	700	750	800	850	900	950	1000	1100
1200	1300	1400	1500	1600	1700	1800	2000	3000	4000

* Possible between 100 to 20.000 mm

4. CONNECTIONS

4.1. Pin Connections

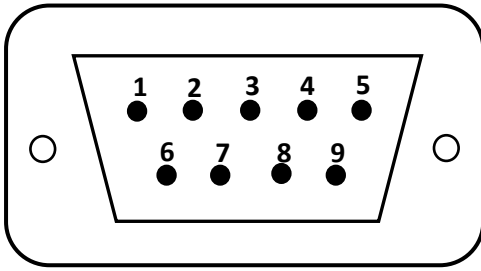

In the following table the cable colors of sensors output signals are given. If the control circuit is suitable in the Line Driver sensors of the not output signals (/A, /B, /Z) have to be added to the system. If it is not suitable /A, /B, /Z signal cables must be fixed as insulated separately. Don't forget that these edges have electricity too.

Pin Number	Cable Color	Signal
1	Yellow	A
2	White	/B
3	Red	+V
4	Black	0V
5	Blue	/A
6	Green	B
7	Grey	/Z
8	Pink	Z
9	Shield	Earth

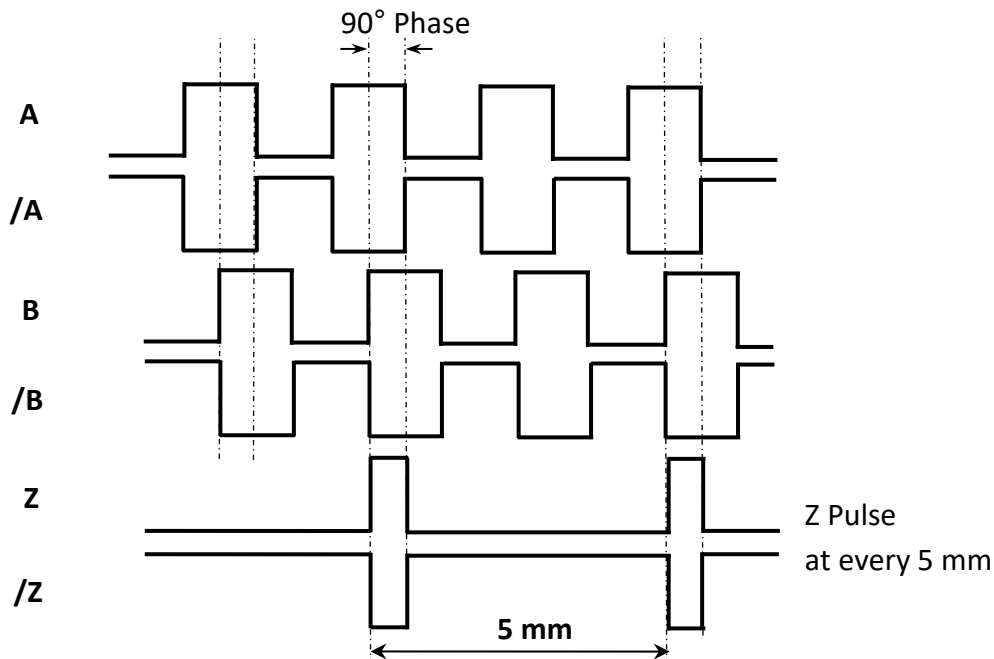

4.2. Installing

The proper installation of MLC 310 is very important issue in terms of the system work properly. The proper installation is shown down. Up surface of the sensor must be down for negative factors. Protection plate must be used. Reader sensor and profile must be parallel for all the stroke. Comparator must be used when installing the scale.

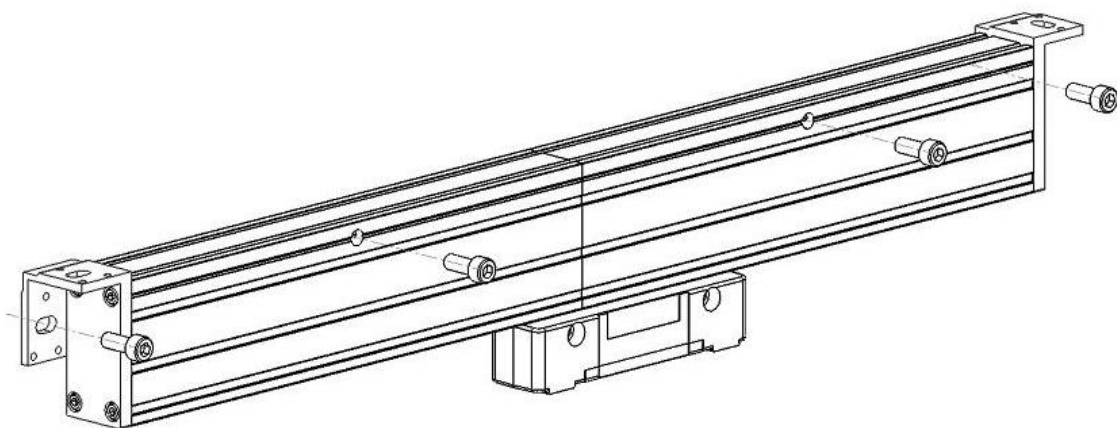
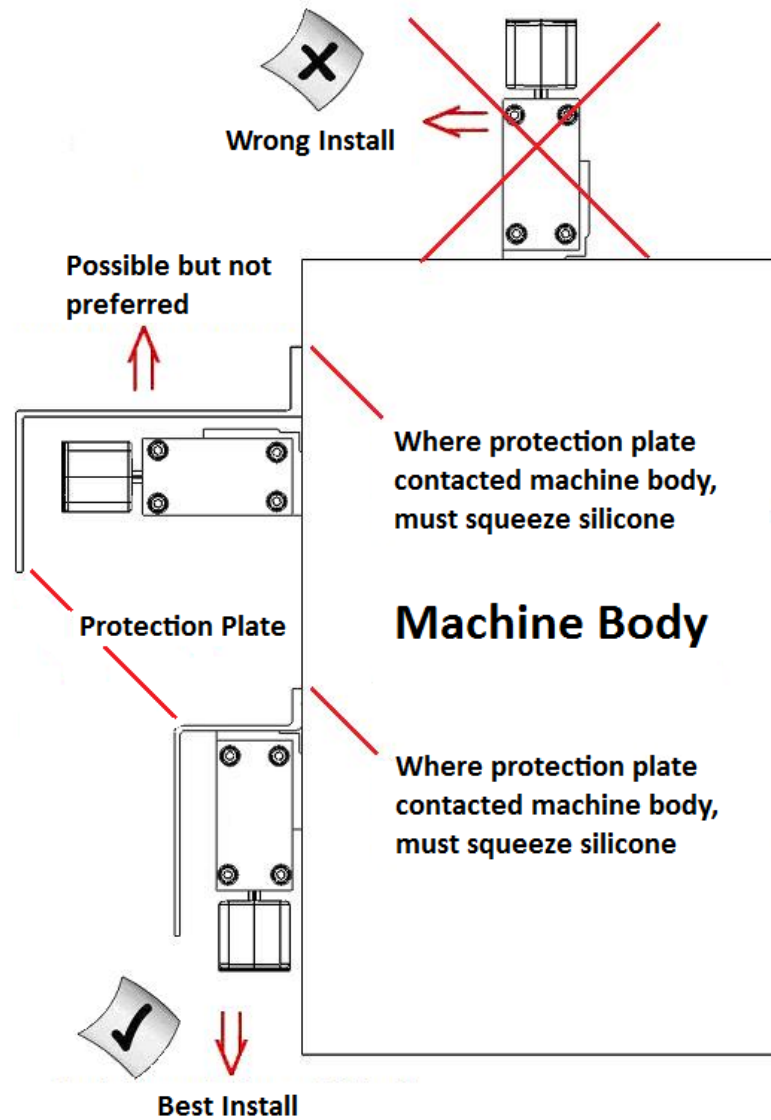

Fixing the scale profile with M4 Screw

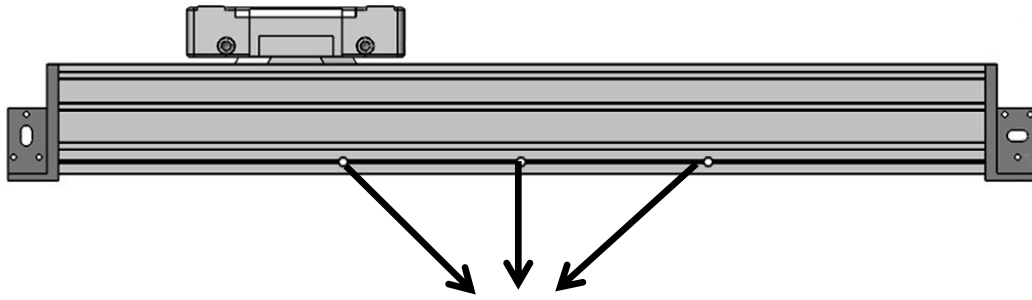

For long scale installations, generally it is not enough to fix the scale in 2 ends. In such cases, mounting holes can be opened over the lowest line on the ruler profile. Mounting holes can be opened from the desired location along the line with a diameter of 6 mm. Thus, long rulers can be secured in a healthy way.

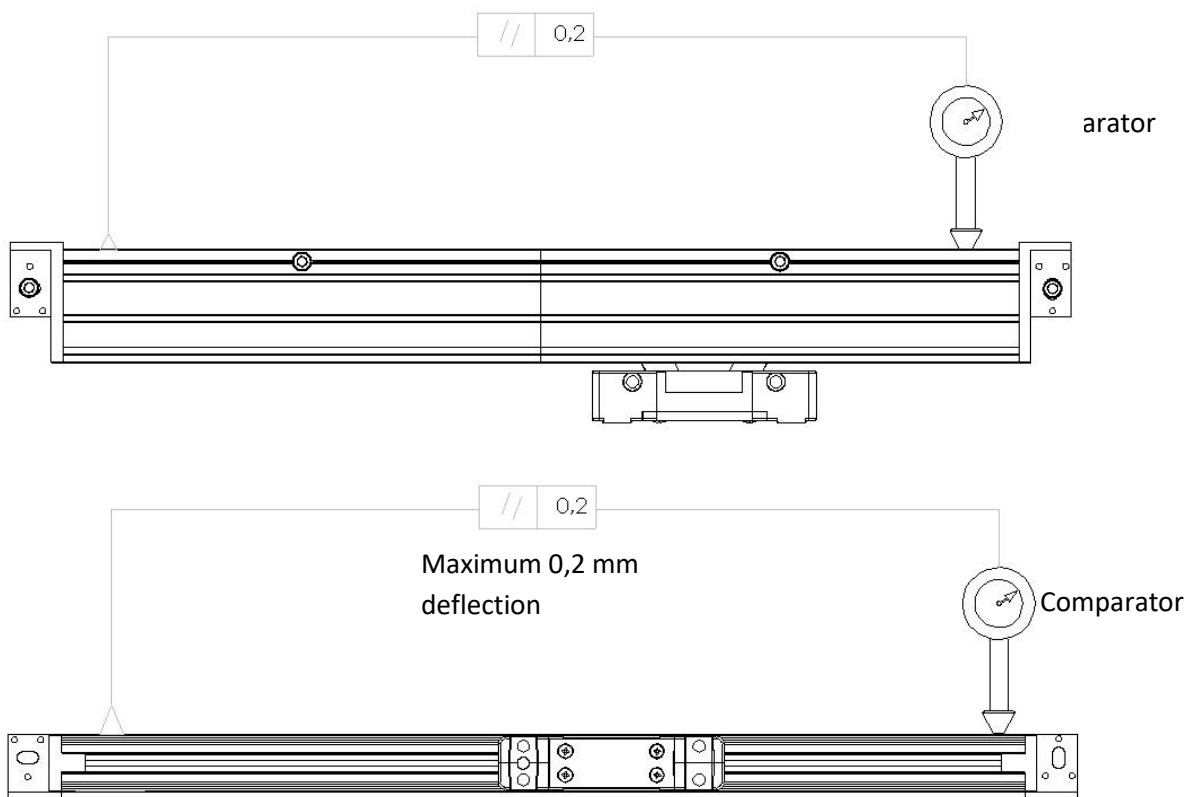

Warning: Take away the comparators magnetic surface from scale profile when installing.

Example DRO Application

Atek ADR 10-3 Digital Readout

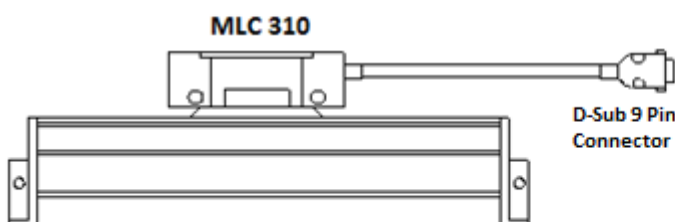

The rear panel of DRO

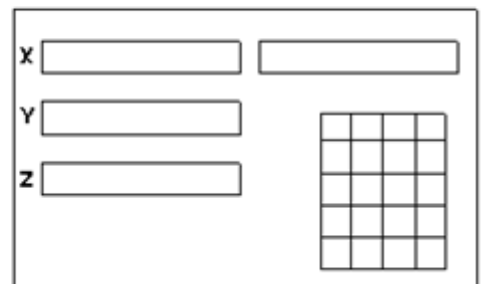
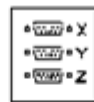

Example PLC Application

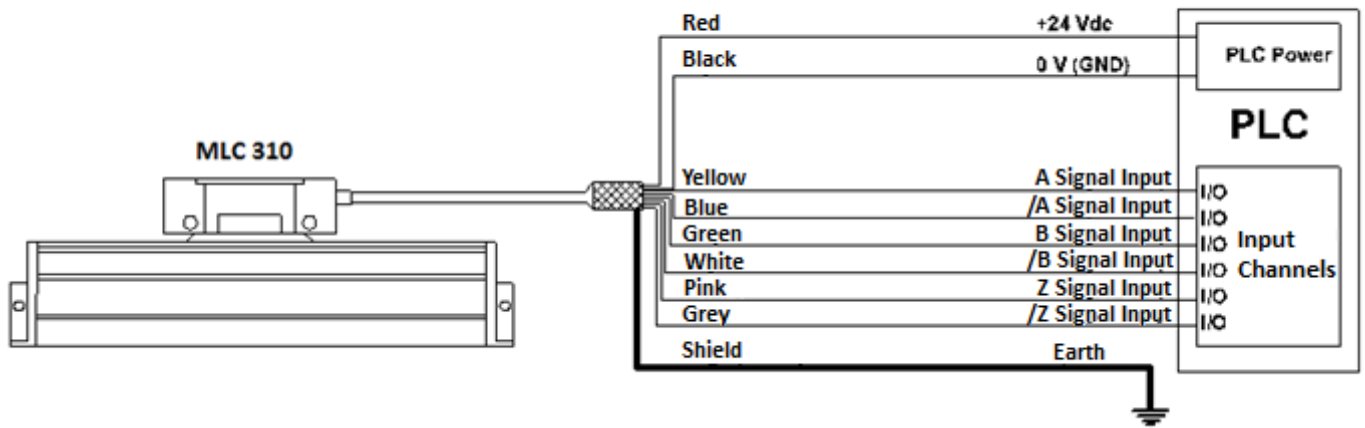

*Other Socket Connections

S41 Socket

Pin Number	Cable Color	Signal
1	RED	POWER SUPPLY
2	BLACK	GROUND
3	YELLOW	A
4	PINK	Z
5	GREEN	B
6	WHITE	/B
7	GREY	/Z
8	BLUE	/A
9	-	-

S87 Socket

Pin Number	Cable Color	Signal
1	-	-
2	RED	POWER SUPPLY
3	BLACK	GROUND
4	BLUE	/A
5	YELLOW	A
6	WHITE	/B
7	GREY	/Z
8	PINK	Z
9	GREEN	B

S86 Socket

Pin Number	Cable Color	Signal
1	PINK	Z
2	GREEN	B
3	YELLOW	A
4	-	-
5	BLACK	GROUND
6	GREY	/Z
7	WHITE	/B
8	BLUE	/A
9	RED	POWER SUPPLY

S71 Socket

Pin Number	Cable Color	Signal
1	BLACK	GROUND
2	BLUE	/A
3	WHITE	/B
4	GREY	/Z
5	RED	POWER SUPPLY
6	YELLOW	A
7	GREEN	B
8	PINK	Z
9	-	-

S57 Socket

Pin Number	Cable Color	Signal
1	YELLOW	A
2	BLUE	/A
3	-	-
4	PINK	Z
5	GREY	/Z
6	-	-
7	-	-
8	BLACK	GROUND
9	-	-
10	GREEN	B
11	WHITE	/B
12	-	-
13	-	-
14	-	-
15	RED	POWER SUPPLY

S43 Socket

Pin Number	Cable Color	Signal
1	YELLOW	A
2	BLUE	/A
3	GREEN	B
4	WHITE	/B
5	PINK	Z
6	GREY	/Z
7	-	-
8	-	-
9	RED	POWER SUPPLY
10	-	-
11	BLACK	GROUND
12	-	-
13	-	-
14	-	-
15	SHIELD	GND

ATEK ELEKTRONİK SENSÖR TEKNOLOJİLERİ SANAYİ VE TİCARET A.Ş.

 Gebze OSB, 800. Sokak, No:814 Gebze/KOCAELİ/TURKEY

 Tel: +90 262 673 76 00

 Fax : +90 262 673 76 08

 Web: www.ateksensor.com

 E-Mail: info@ateksensor.com