



ALC 77-B



- 74X74 MM DIMENSIONS
- 2 ROW, 7 DIGITS DISPLAY
- A VE B COUNT INPUTS
- FUNCTIONAL EXTERNAL Z (RESET) INPUT
- FUNCTIONAL EXTERNAL HOLD INPUT
- 2 PIECES DOUBLE RELAY OUTPUT
- SELECTION OF 8 DIFFERENT INPUT TYPES
- 10 DIFFERENT OUTPUT CONTROL MODE WITH 6 COUNTER + OUTPUT 4 BATCH
- 5 VDC OR 12 VDC SENSOR SUPPLY OUTPUT
- ENTERING THE OFFSET VALUE
- PASSWORD SECURITY

USER MANUAL

INDEX

1. TECHNICAL FEATURES	1
2. CONNECTIONS	2
3. DESCRIPTION OF FRONT PANEL.....	4
4. DEVICE PROGRAMMING	5
4.1. Entering Set Value to Device (Set).....	5
4.2. Selection of Counter Type-Batch/Counter- (Distype).....	6
4.3. Selection of Input Type – Forward/Backward (Cnt_typ).....	6
4.4. Relay Output Mode (Output).....	7
4.5. Relay Output Time (tout).....	8
4.6. Relay Output Positions (out).....	8
4.7. Selection of Input Frequency Input (in_freq).....	8
4.8. Entering Offset Value(offset).....	9
4.9. Demonstration of the Total Value of the Counter(total).....	9
4.10. Selection of the Reset value of the counter (Cnt rst).....	9
4.11. Batch Reset (bat rst).....	10
4.12. Reset of Total Value (tot rst).....	10
4.13. Reset With Button (rst btn).....	10
4.14. Reset with External Z Signal (rst inpt).....	11
4.15. Activating The Hold Input (Hold).....	11
4.16. Selection Sensor Type (NPN/PNP) (Sensstyp).....	11
4.17. Return to Factory Defaults (Factory).....	12
4.18. Keeping in memory when the power fails (Data).....	12
4.19. Password Protection (Code_in).....	13
4.20. Annex A – Graphics of Input Signal Types (Output Menu).....	14
4.21. Annex B – Graphics of RELAY OUTPUT Types (Output Menu).....	15
5. CERTIFICATE of WARRANTY	17

1. TECHNICAL FEATURES

ELECTRICAL CHARACTERISTICS

SUPPLY VOLTAGE	24 VAC/DC 50/60 Hz 85-265 VAC 50/60 Hz
POWER CONSUMPTION	5.5 VA / 4.4 W Max
SENSOR SUPPLY VOLTAGE	5 VDC 100 mA (for TTL Sensor) 12 VDC 100 mA (for Push-Pull Sensor)
CONNECTION	2,5 mm ² screw-clemens
INPUTS	A/B Encoder Pulse Inputs (600 KHz speed reading) Z (external reset) Input Hold Input
OUTPUTS	2 pieces 250 VAC 3A (for Resistive Load) Relay

PHYSICAL CHARACTERISTICS

DIMENSIONS	74 x 74 x 79 mm
WEIGHT	300 gr.
MOUNTING	Upper and lower legs are fixed to the clipboard.
RELATIVE HUMIDITY	%80 up to 31 °C , %50 up to 40 °C
STORAGE TEMPERATURE	-10 UP TO 60 °C
OPERATING TEMPERATURE	0 UP TO 50 °C
PROTECTION CLASS	IP 60 Front Panel, IP 20 Back panel

DIMENSIONS

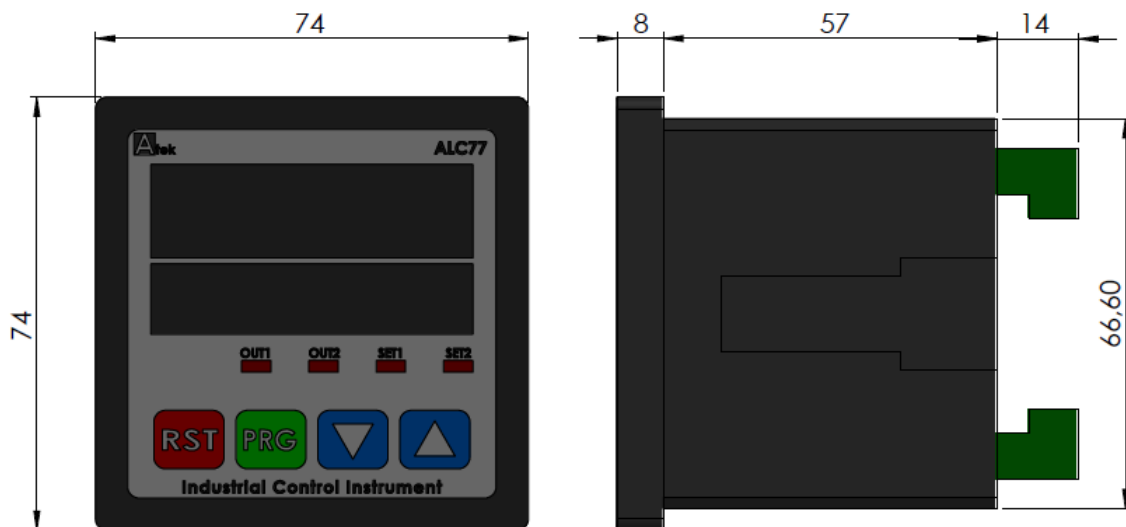

2. CONNECTIONS

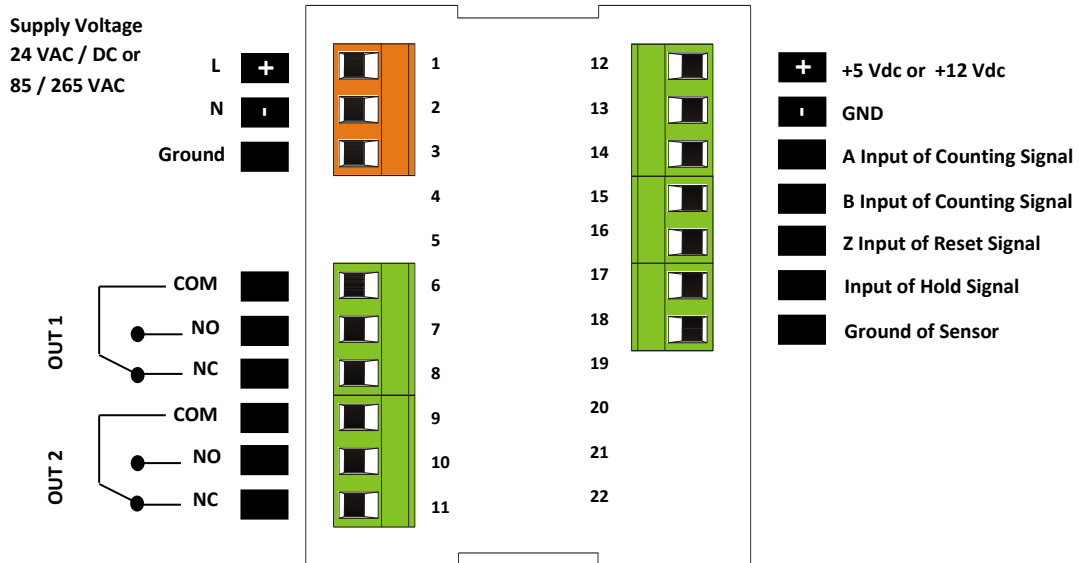

SAFETY WARNINGS

1. Follow the instructions and warnings in the user guide.
2. Please check the type of power supply, before connect energies the device.
3. Please the device mounted on panel against dangers of fall, snap, shake during working.
4. Make Sensor connections without energy on the device, do not connect in any way during operation.
5. Make sure that is shielded cables between device and sensor.
6. Do not leave the device exposed to a heat source (solar, heater etc.)
7. ALC77 industrial control device is not suitable for use in the external environment, Use only room conditions.
8. Wipe with a damp cloth to clean the device, do not use water, thinner etc.
9. Comply with the limit values specified in the technical specifications for relay outputs.
10. The device cannot be changed by the user in the event of a fault, Please contact our technical service in case of failure.

CONNECTING OF THE PROXIMITY SENSOR

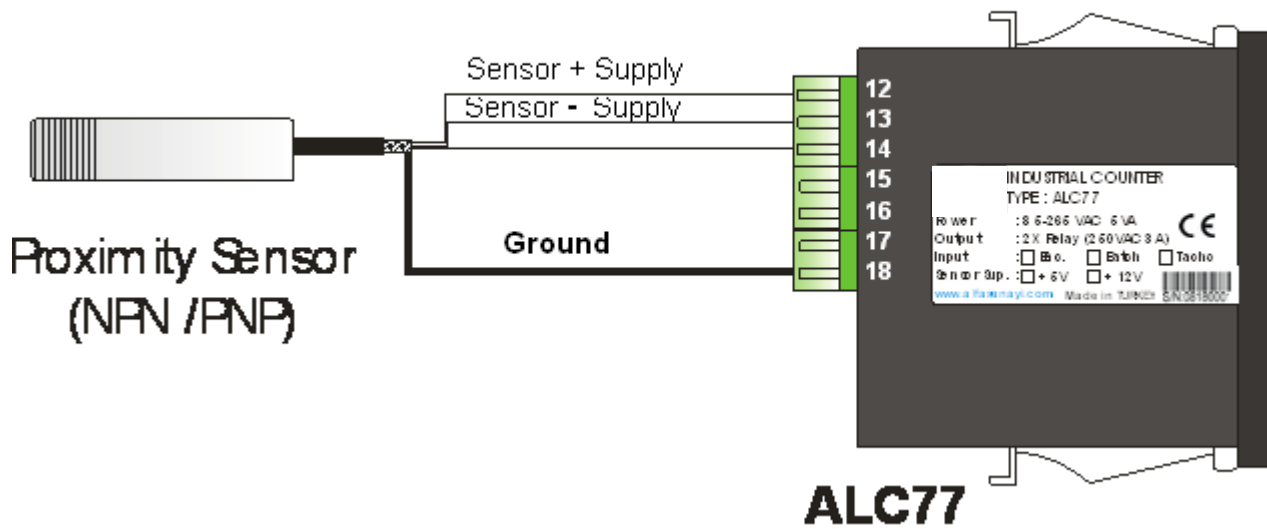

CONNECTING OF COUNTING WITH SWITCHING

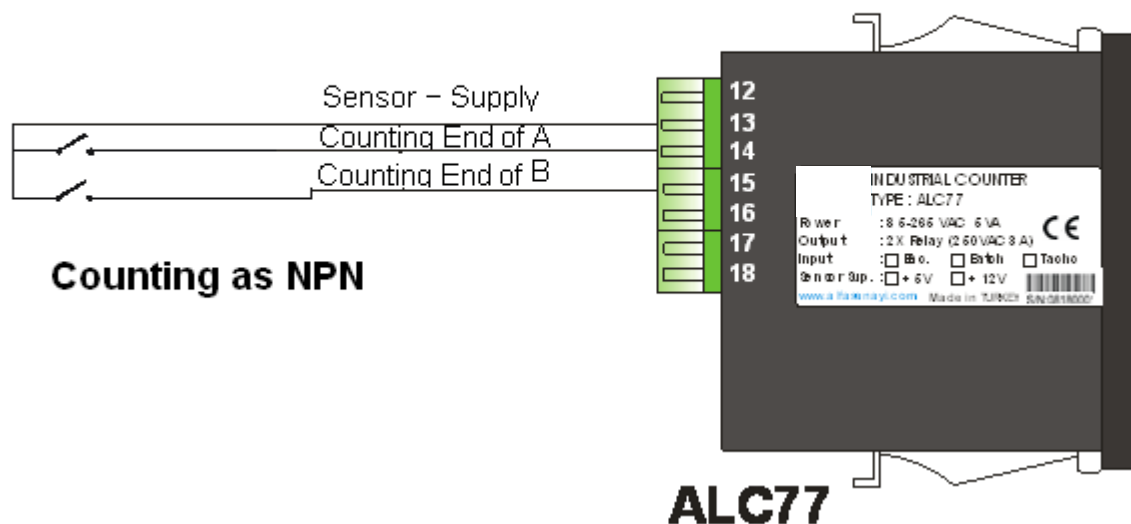
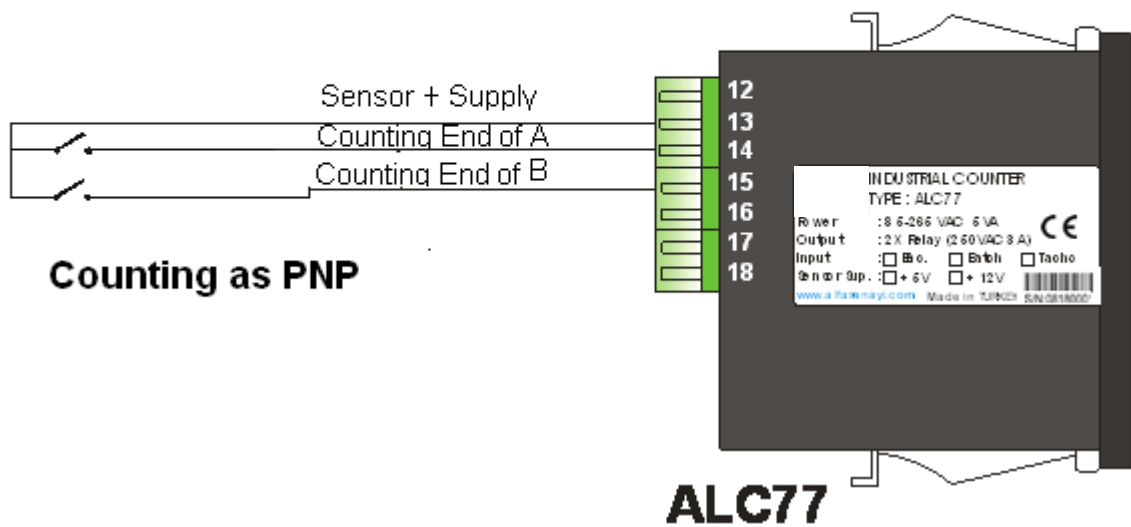

3. DESCRIPTION OF FRONT PANEL

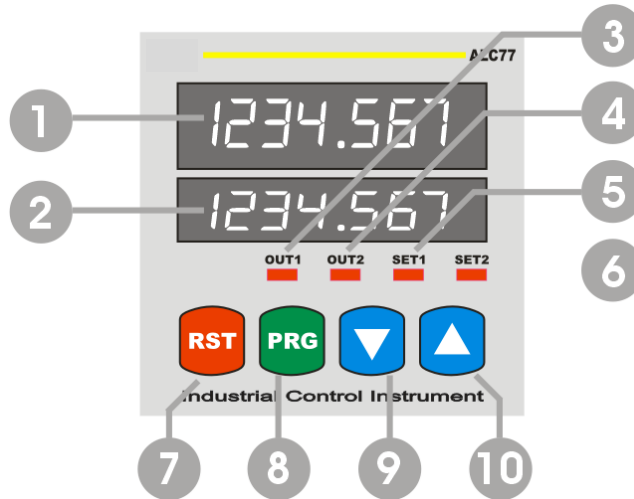

ALC77 device operates in 2 different modes:

Programming mode : Specifies the function used during programming.

Operating modu : Specifies the function used during operating.

Display and Position LEDs

1. 7 Digit LED Display (9,2mm) **at operating mode:** Indication of counting
At programming mode: Indication of program parameter
2. 7 Digit LED Display (7mm) **at operating mode:** Indication of Set value.
At programming mode: Indication of program parameter
3. Out-1 output LED position: On while the power at Out-1.
4. Out-2 output LED position: On while the power at Out-2.
5. Set-1 Led position: On while Set-1 value is displayed in the bottom display
6. Set-2 Led position: On while Set-2 value is displayed in the bottom display.

Button Functions

7. RESET Button **at operating mode:** Used to reset of counted value.
At programming mode: Using to exit without saving the entered value of the parameter and return to the operation mode.
8. PROG Button **at operating mode:** Used to return to the menu.
At programming mode: Used to save and enter menu parameter value.
9. Down Button **at operating mode:** Used to in the bottom display to show the value of Set-1.
At programming mode: Used to switch between the menus and decrease the value of the selected parameter.
10. Up Button **at operating mode:** Used to in the bottom display to show the value of Set-2.
At programming mode: Used to switch between the menus and decrease the value of the selected parameter.

4. DEVICE PROGRAMMING

Enter to the menu and Changing Parameters:

For Switch to programming mode while device operating mode push (PRG) button. Firstly "SET-1" menu will appear on the screen.



Switch between program menus with Down (▼) and up (▲) buttons. PRG button is entered into for the menu to be changed. Changes can save with prg (PRG) button. Return to operating mode with Rst (RST) button. If password protection is activated at device, password must be entered. If password is correct, true message is displayed on the bottom line. Also password is incorrect, "false" is displayed.

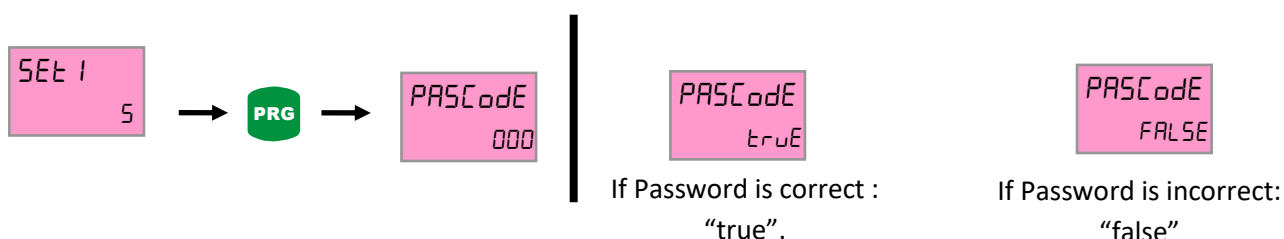

4.1. Entering The Set Point to Device (Set)

Menu is displayed firstly on the screen as prg button is pressed while operating mode. Menu of Set 2 is displayed while down button is pressed. The top row shows the name of the menu and bottom row also (yellow marked) selected value in menu content. Set 1, set 2 allows controlling to out1 and out2 relays.

Move to the desired set point for setting. The rightmost digit starts flashing when Prg button is pressed. Desired point is selected up and down button. Used to Prg button for digits scrolling. Shifted to the left for one step when each press of the button, If pres the prg button when coming the rightmost digits, positive or negative value will be asked. Value is selected by up and down button then saved with prg button. If you are not want to save, you can exit with esc button.

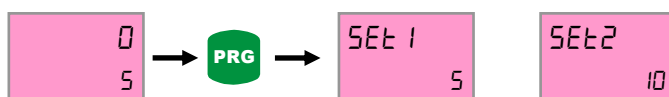

4.2. Selection of Counter Type-Batch/Counter- (Dsptype)

This menu allows you to set the device type counter. There are two types of counter mode, "Counter" and "Batch". At Batch or Counter mode, The counter counts forward or reverse according to signals of A and B channel depending on the type of the selected input. Besides counting is done as part, counting operation is performed according to the amount of part. The contents of the output menu will vary according to counter type selected.

In order to determine counter type, entered to device menu with prg button at operation mode. Found to Dsptype menu with up-down button and pressed to prg button then bottom row choice flashes. Make the selection with up-down button and saved value by prg button. Then return with rst button to operating mode.



4.3. Selection of Input Type – Forward/Backward (Cnt_Typ)

The input type is selected and that determines the type of counting according to signals of A and B Channel depending on the type of the selected input. There are 8 different counting options. For detailed information refer to annex part at the end of the manual. In order to select counter type, pressed to prg button at operation mode. Found to Cnt_typ menu with up-down button and pressed to prg button then bottom row choice flashes. Make the selection with up-down button and saved value by prg button. Then return with rst button to operating mode.

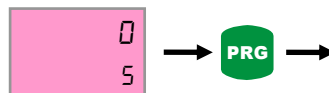

Cnt_tYP
uP_dn increases with A signal,
reduced with B signal.

Cnt_tYP
uP_d ir Increases with A signal,
A signal counts reverse, as long as becomes the B signal

Cnt_tYP
uP_uP increases with A signal,
increases with B signal.

Cnt_tYP
dn_d ir Reduced with A signal,
A signal counts forward, as long as becomes the B signal.

Cnt_tYP
dn_uP Reduced with A signal,
Increases with B signal.

Cnt_tYP
uP_gt Increases with A signal,
A signal do not counti as long as becomes the B signal.

Cnt_tYP
dn_dn Reduced with A signal,
Reduced with B signal.

Cnt_tYP
dn_gt Reduced with A signal,
A signal do not counti as long as becomes the B signal.

4.4. Relay Output Modes (Output)

There are 10 different (6 pieces counter, 4 pieces batch) output type at output menu. If counter type is selected "counter", selection menu 0 up to 5 is displayed on the bottom line of output menu. Choices are described below. For detailed information refer to annex part at the end of the manual. Press to prg button at operation mode. Found to output menu with up-down button and pressed to prg button then bottom row choice flashes. Make the selection with up-down button and saved value by prg button. Then return with rst button to operating mode.

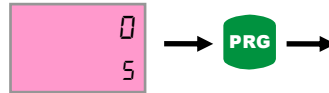

outPut
0

The relay function is turned off.

outPut
1

When passed over Set1 value, Output1 will be active.

When passed over Set2 value, Output2 will be active.

outPut
2

When passed over Set1 value, Output1 will be active.

When passed over Set2 value, Output2 will be active. Counter will be Hold position as long as without reset.

outPut
3

When passed over Set1 value, Output1 will be active.

When passed over Set2 value, Output2 will be active. So Output1 is not active.

outPut
4

When passed over Set1 value, Output1 will be active.

When passed over Set2 value, Output2 will be active. Out1 will be inactive and the value on the screen returns to the ofset value.

outPut
5

When passed over Set1 value, Output1 will be active.

When passed over Set2 value, Output2 will be active. Out1 is not active. And then and the value on the screen returns to the ofset value.

If batch is selected as the counter type, the following choices appear in the output menu. Choices are described below. For detailed information refer to annex part at the end of the manual:

outPut
batch-1

When passed over Set1 value, Output1 will be active. the value on the screen returns to the ofset value and batch value increases . When Batch value reaches to set2 value, out2 will be active.

outPut
batch-2

Reached to offset value whileAt Set1 value, Out1 will be active. The value on the secreen returns to Set1 value and Batch value increases. When Batch value reaches to set2 value , out2 will be active.

outPut
batch-3

When passed over Set1 value, Output1 will be active . The value on the secreen returns to Set1 value and Batch value increases. When Batch value reaches to set2 value , out2 will be active. IF hold is set as Out2 relay time, counter will switch hold position and do not count without resetting.

outPut
batch-4

Reached to offset value whileAt Set1 value, Out1 will be active. The value on the secreen returns to Set1 value and Batch value increases. When Batch value reaches to set2 value , out2 will be active. IF hold is set as Out2 relay time, counter will switch hold position and do not count without resetting.

4.5. Relay Output Time (tout)

Tout menus allow relay output times according to entered times. If entered time is zero, it will hold on the screen. Thus situated, relays will be active during the set value is exceeded. In order to enter output time, if you press the prg button, find tout1 or tout2 menus with up-down button. When press prg button, the right-digit of bottom row flashes. Its value is set with up-down button. Each press of the button moves to the left in a digit. Then you can save them. Therefore point is fixed.

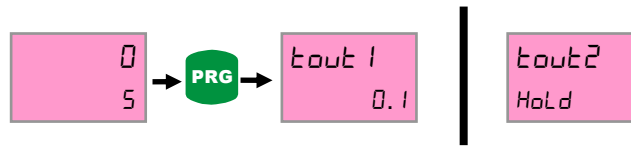

4.6. Relay Output Positions (out)

Out1 and out2 menus allow positions of the relays. The relay is inactive at Nclose option, active while reached set point. And also the relay is active at Nopen option, it will be inactive while reached set point.

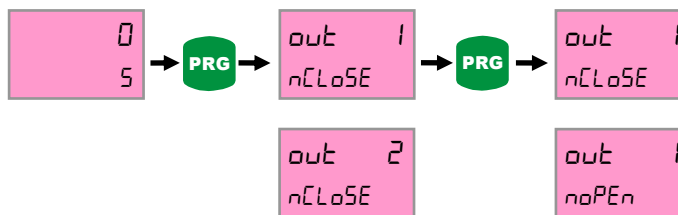

4.7. Selection Of Input Frequency (in_freq)

Used to input frequency filtering for prevent undesired interference. Frequencies of above from the selected value is not detected by the counter. In order to select input frequency, pressed to prg button at operating mode. Found in_freq menu with up-down button and pressed to prg button then bottom row choice flashes. Make the selection with up-down button and saved value by prg button. Then return with rst button to operating mode.

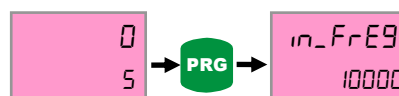

4.8. Entering Offset Value (offset)

Offset value can be entered using this menu to device. Return to entered offset value when pressed to rst button or signal comes from Z input. If offset value is zero and reset button is pressed, zero will write on the screen. Found offset menu with up-down button and pressed to prg button then bottom row choice flashes. Set to value with up-down button and each press of the button moves to the left in a digit. Then you can save them.



4.9. Demonstration of the Total Value of the Counter (total)

This menu determines to display which values on the screen. In order to select value, pressed to prg button at operating mode. Found total menu with up-down button and pressed to prg button then bottom row choice flashes. Change to option with up-down button and save choice with prg button then return to operation mode with rst button.



- Counter** : Shows the value of the counter.
- Out1** : Shows number of Relay-1 operating.
- Out2** : Shows number of Relay-2 operating.
- Nototal** : The function doesn't work.

4.10. Selection Of The Reset Value Of The Counter (Cnt Rst)

Cnt Rst menu determines the value of the counter will be zero or not zero. If it's on position, the value can be reset or if it's off position, counter does not reset. In order to select choice, pressed to prg button at operating mode. Found Cnt Rst menu with up-down button and pressed to prg button then bottom row choice flashes. Change to option with up-down button and save choice with prg button then return to operation mode with rst button.

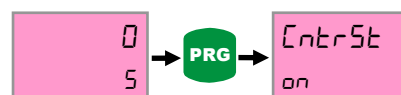

4.11. Batch Reset (bat rst)

Batch Rst menu determines to reset of batch value when pressed up-down button for two times at operating mode. If bat rst is "on" position, pressing the reset button for about 2 seconds, the value is reset. If it is "off" position, the value is not reset. In order to open batch reset, pressed to prg button at operating mode. Found Bat Rst menu with up-down button and pressed to prg button then bottom row choice flashes. Changed to option with up-down button and save choice with prg button then return to operation mode with rst button.



4.12. Reset of Total Value (tot rst)

Tot rst determines to reset of total value when pressed up-down button for two times at operating mode. If Tot rst is "on" position, pressing the reset button for about 2 seconds, the value is reset. If it is "off" position, the value is not reset. In order to open batch reset, pressed to prg button at operating mode. Found Tot Rst menu with up-down button and pressed to prg button then bottom row choice flashes. Changed to option with up-down button and save choice with prg button then return to operation mode with rst button.



4.13. Reset With Button (rst btn)

This menu allows becoming active RST button on the front panel. While RST button is active, the value of the on-screen will be reset when pressed up-down button for two times at operating mode or return to offset value. In order to open RST button, pressed to prg button at operating mode. Found Tot Rst menu with up-down button and pressed to prg button then one of reset/noreset choice at bottom row flashes. Change to option with up-down button and save choice with prg button then return to operation mode with rst button.

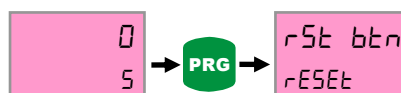

4.14. Reset With External Z Signal (rst inpt)

Resetting at device screen can be done with by applied from outside external an encoder Z signal or a switch when External Z input is be activated. While you make active the Z input, select the edge you will make reset on. You can select one of rising and falling edges. If you don't want to use Z input, select to noreset option. In order to activate to Z input, pressed to prg button at operating mode and found rst inpt menu with up-down button. When Prg button is pressed, options will flash and made the selection with up-down button. Then save it by prg button.



4.15. Activating The Hold Input (Hold)

While hold input is active, value on the screen is fixed when coming the signal of hold input. If signal of hold input isn't cut, counting can not to be continued. While you select the hold input, also select the edge you will make reset on. You can select one of Rising and falling edges. If you want to hold off Input, select to off option. In order to select to Hold Input, pressed to prg button at operating mode and found hold menu with up-down button. When prg button is pressed, options will flash and made the selection with up-down button. Then save it by prg button.

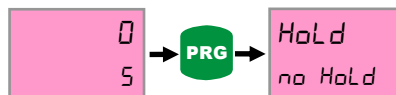

4.16. Selection Sensor Type (Npn/Pnp) (Senstyp)

The used sensor type can be select from this menu. The sensor output signal is selectable as NPN or PNP. In order to selected sensor type, pressed to prg button at operating mode and fount S.typ menu with up-down button. When prg button is pressed, options will flash and made the selection with up-down button. Then save it by prg button and return with rst button to operating mode.



4.17. Return To Factory Defaults (Factory)

Factory menu enables to return the first fabrication settings of device. At this situation, all device settings will change and for this reason important settings should be saved previously. Device will require the password for returning to factory defaults and this password is 454. In order to return to factory defaults, pressed to prg button at operating mode and found to factory menu with up-down button. When prg button is pressed at menu screen, The right-digit of bottom row is flashing and changed value with up-down button. When pressing to prg button, moves to the left in a digit and you can set it as 454 and press to prg button. So device will return to factory defaults.

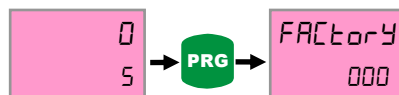

4.18. Keeping In Memory When The Power Fails (Data)

Data menu enables to keep in memory the last value on the screen even if the energy is cut off and must be selected record for this option. So the final value will be memorized when energy is cut off and resumes again when energy comes back. Recording process will not be stored to device memory while clear is selected, and then value will start from zero. In order to change data menu, pressed to prg button at operating mode and found data menu with up-down button. Then save it by prg button and return with rst button to operating mode.



4.19. Password Protection (Code_in)

Password security enables that unauthorized persons is prevented to change the parameters of the menu. If Code-in menu is on position, you can enter to device's menu and password is required for any setting changes. If the password is wrong, you cannot change anything. While Code_in menu is off, the password protection is not active. If Code_in menu is on, recode is added to menu titles. In order to turn on Code-in menu, pressed to prg button at operating mode and found Secu Menu with up-down button. Then save it by prg button.

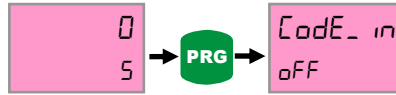

When Code_in menu is on position, recode is added to menu titles. Recode menu enables identification of password to device. Default password is 000, if you have not changed.

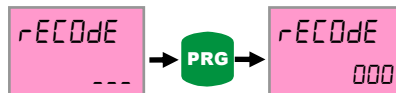

When prg button is pressed at menu screen, the right-digit of bottom row is flashing and changed value with up-down button. When Pressed to prg button, moves to the left in a digit. So you can set the value with up-down button and save them when pressed to prg button at third digit. So password is defined.

INPUT TYPES

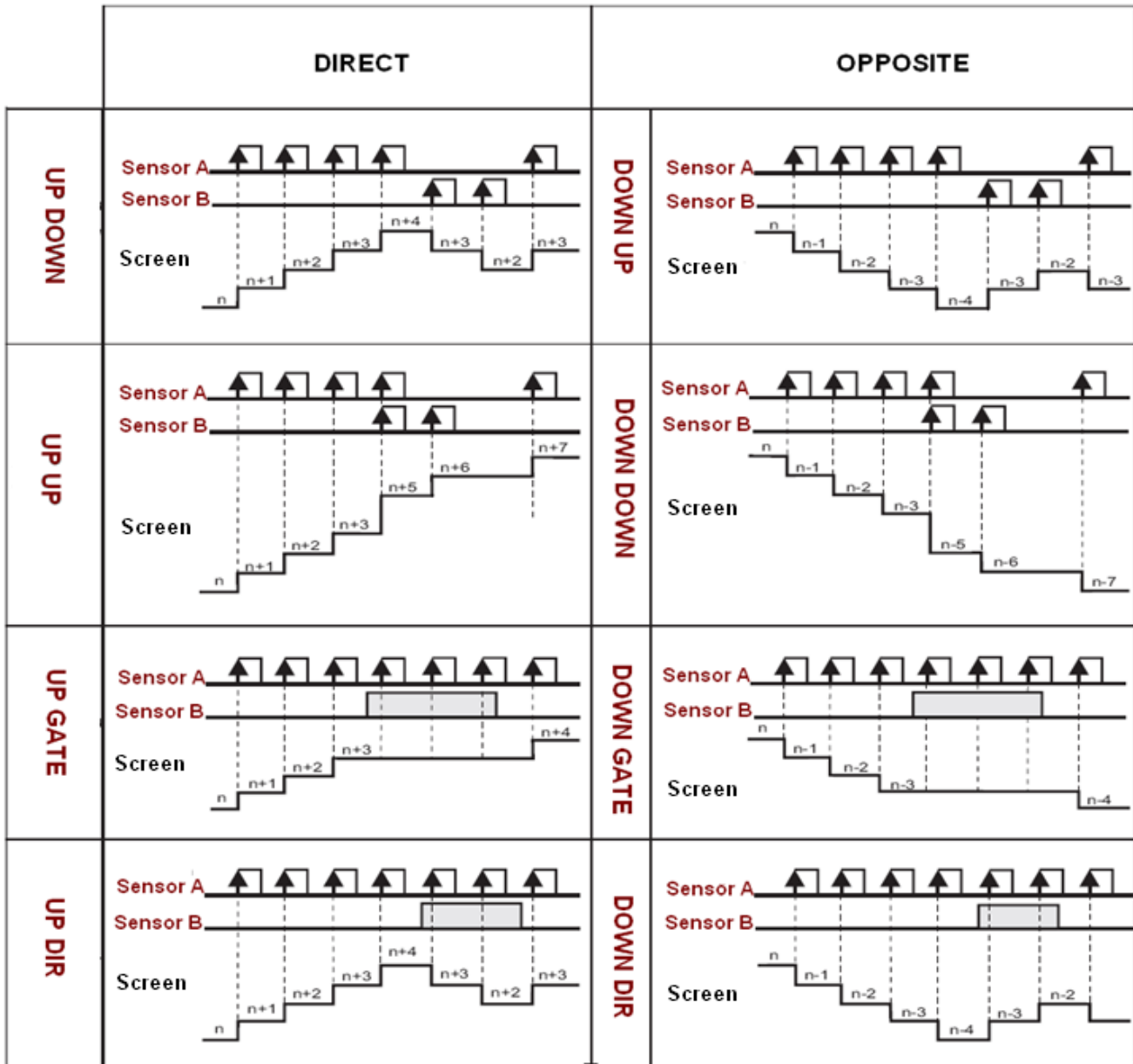

4.21. Annex B – Graphics of Relay Output Types (Output Menu)

OUTPUT TYPES

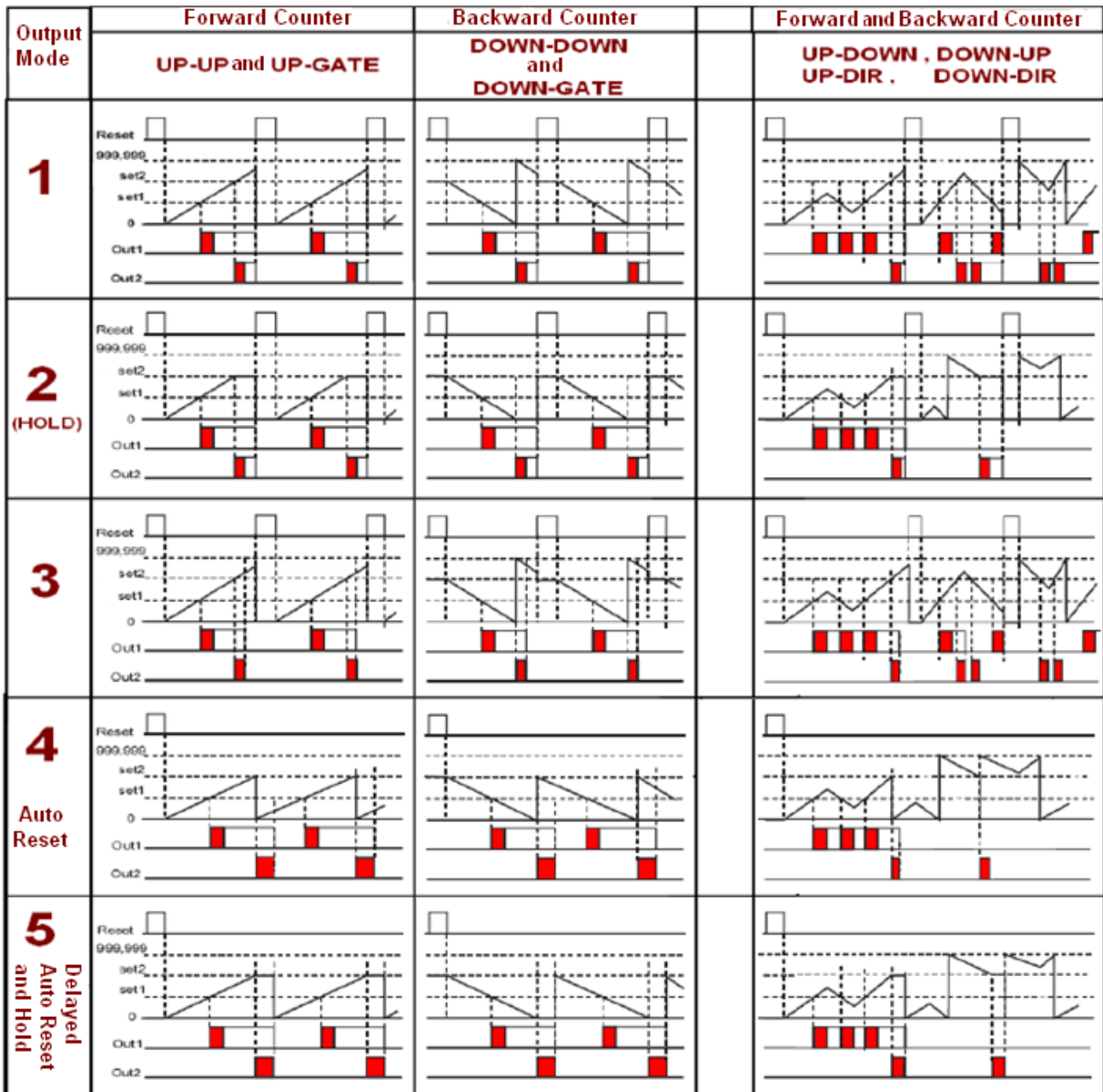

BATCH OUTPUT MODES

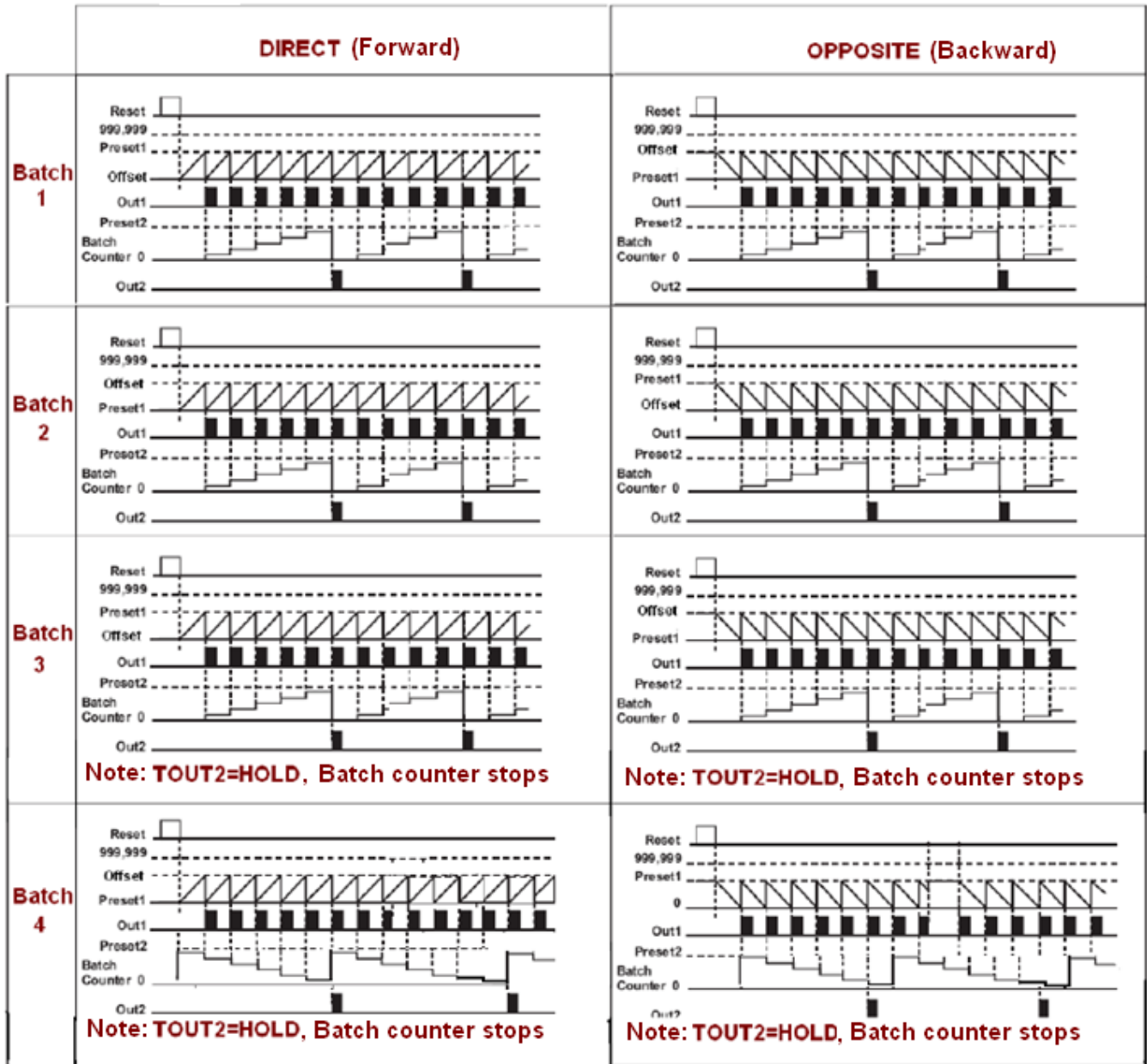

5. CERTIFICATE OF WARRANTY

Product : **ALC77 B** 85/265 VAC 24 VAC/DC
TTL Push Pull

Serial No :

This product is guaranteed for two years against manufacturing defects.
Conditions out of the warranty:

- Mechanical damage
- Shipping damage
- Users error

Other situations are covered by the manufacturer's warranty.

Signature and Stamp



ATEK ELEKTRONİK SENSÖR TEKNOLOJİLERİ SAN. VE TİC. A.Ş.

 Gebze OSB, 800. Sokak, No:814 Gebze/KOCAELİ/TURKEY

 Tel: +90 (262) 673 76 00

 Fax : +90 (262) 673 76 08

 Web: www.ateksensor.com

 E-Posta: info@ateksensor.com